

Design of Observers for Hybrid Systems ^{*}

Andrea Balluchi¹, Luca Benvenuti²,
Maria D. Di Benedetto³, and Alberto L. Sangiovanni-Vincentelli^{1,4}

¹ PARADES, Via di S. Pantaleo, 66, 00186 Roma, Italy.

`balluchi,alberto@parades.rm.cnr.it`

² DIS, Università di Roma “La Sapienza”, Via Eudossiana 18, 00184 Roma, Italy.

`luca.benvenuti@uniroma1.it`

³ DIE, Università dell’Aquila, Poggio di Roio, 67040 L’Aquila, Italy.

`dibenede@ing.univaq.it`

⁴ EECS, University of California at Berkeley, CA 94720, USA.

Abstract. A methodology for the design of dynamical observers for hybrid plants is proposed. The hybrid observer consists of two parts: a *location observer* and a *continuous observer*. The former identifies the current location of the hybrid plant, while the latter produces an estimate of the evolution of the continuous state of the hybrid plant. A synthesis procedure is offered when a set of properties on the hybrid plant is satisfied. The synthesized hybrid observer identifies the current location of the plant after a finite number of steps and converges exponentially to the continuous state.

1 Introduction

The state estimation problem has been the subject of intensive study by both the computer science community in the discrete domain (see [14, 6, 12]), and the control community in the continuous domain (see the pioneering work of Luenberger [10]), but has been scantily investigated in the hybrid system domain.

The authors investigated for years the use of a hybrid formalism to solve control problems in automotive applications (see [3]). The hybrid control algorithms developed are based on full state feedback, while only partial information about the state of the hybrid plant is often available. This motivates this work on the design of observers for hybrid systems. Some partial results are given in [4], where an application to a power-train control problem is considered. In this paper, the authors present a general procedure to synthesize hybrid observers.

The literature on observers design in the discrete and the continuous domain is rich. Here we briefly summarize some of the results that are relevant for our presentation. In the control literature, Ackerson first introduced in [1] the state estimation problem for switching systems, represented as continuous systems

^{*} The work has been conducted with partial support of PARADES, a Cadence, Magneti-Marelli and ST-microelectronics E.E.I.G, by the European Community Projects IST-2001-33520 CC (Control and Computation) and IST-2001-32460 HYBRIDGE, and by CNR PF-MADESSII SP3.1.2.

subject to a known dynamics taken from a set of given ones and with no state resets. Subsequently, state estimation was considered by several authors in a probabilistic framework (see e.g. [17]). Gain switching observers for nonlinear systems were studied in [8].

In the discrete systems literature, Ramadge gave in [14] the definition of current–location observability for discrete event dynamic systems, as the property of being able to estimate the current location of the system, after a finite number of steps from the evolution of the input and output signals. A well–known approach for the estimation of the current location of an automaton is the computation of the so-called *current–location tree*, described in [6], that gives the subset of locations the system can be in at the current time. Interesting results on location estimation for discrete systems are also presented in [12], where a slightly different definition of observability is used.

In [2], Alessandri and Coletta considered the problem of observers design for hybrid systems, whose continuous evolution is subject to linear dynamics assuming knowledge of the discrete state at each time.

In this paper, the assumption on discrete state knowledge is removed and the more general case where only some hybrid inputs and outputs (both either discrete or continuous) of the hybrid plant are measurable is addressed. The objective is to devise a hybrid observer that reconstructs the complete state from the knowledge of the hybrid plant inputs and outputs, achieving generation of the plant location sequence and exponential convergence of the continuous state estimation error.

As described in Section 2, the proposed hybrid observer consists of two parts: a *location observer* and a *continuous observer*. The former identifies the current location of the hybrid plant, while the latter produces an estimate of the evolution of the continuous state of the hybrid plant. In Section 3, it is first tackled the case where the current location of the given hybrid plant can be reconstructed *using the discrete input/output information only*, without the need of additional information from the evolution of the continuous part of the plant. When the evolutions of the discrete inputs and outputs of the hybrid plant are not sufficient to estimate the current location, the continuous plant inputs and outputs can be used to obtain some additional information that may be useful for the identification of the plant current location. This case is treated in Section 4. Due to space limitation, some proofs are not reported. They can be found in the extended version of the paper available at the PARADES’ web page <http://www.parades.rm.cnr.it>.

2 Structure of the hybrid observer

Let H_p denote the model of a given hybrid plant with N locations and let (q, x) , (σ, u) and (ψ, y) stand, respectively, for the hybrid state, inputs and outputs of the plant. Our aim is to design a hybrid observer for the plant that provides an estimate \hat{q} and an estimate \hat{x} for its current location q and continuous state x ,

respectively. We assume that the discrete evolution of q is described as follows:

$$q(k+1) \in \varphi(q(k), \sigma(k+1)) \quad (1)$$

$$\sigma(k+1) \in \phi(q(k), x(t_{k+1}), u(t_{k+1})) \quad (2)$$

$$\psi(k+1) = \eta(q(k), \sigma(k+1)) \quad (3)$$

where $q(k) \in Q$ and $\psi(k) \in \Psi$ are, respectively, the location and the discrete output after the k -th input event $\sigma(k) \in \Sigma \cup \{\epsilon\}$, and t_k denotes the unknown time at which this event takes place. $Q = \{q_1, \dots, q_N\}$ is the finite set of locations with $N = |Q|$, Ψ is the finite set of discrete outputs, Σ is the finite set of input events and internal events depending on the continuous state x and input u , and ϵ is the *silent event*¹. $\varphi : Q \times \Sigma \rightarrow 2^Q$ is the transition function, $\eta : Q \times \Sigma \rightarrow \Psi$ is the output function and $\phi : Q \times X \times U \rightarrow 2^\Sigma$ is the function specifying the possible events where $X \subseteq \mathbb{R}^n$, $U \subseteq \mathbb{R}^m$ are the continuous state and control values domains. Moreover, we assume that the continuous evolution of x is described by a linear time-invariant system

$$\dot{x}(t) = A_i x(t) + B_i u(t) \quad (4)$$

$$y(t) = C_i x(t) \quad (5)$$

with $y(t) \in \mathbb{R}^p$ and $A_i \in \mathbb{R}^{n \times n}$, $B_i \in \mathbb{R}^{n \times m}$, $C_i \in \mathbb{R}^{p \times n}$ depending on the current plant location q_i . Note that the plant hybrid model does not allow continuous state resets.

In this paper we present a methodology for the design of exponentially convergent hybrid observers defined as follows

Definition 1. *Given the model of a hybrid plant H_p as in (1–5) and given a maximum convergence error $M_0 \geq 0$ and a rate of convergence μ , a hybrid observer is said to be exponentially convergent if its discrete state \tilde{q} exhibits correct identification of the plant location sequence after some steps and the continuous observation error $\zeta = \tilde{x} - x$ converges exponentially to the set $\|\zeta\| \leq M_0$ with rate of convergence greater than or equal to μ , that is*

$$\tilde{q}(k) = q(k) \quad \forall k > K, \text{ for some } K \in \mathbb{N}^+ \quad (6)$$

$$\|\zeta(t)\| \leq e^{-\mu t} \|\zeta(t_K)\| + M_0 \quad \forall t > t_K. \quad (7)$$

The structure of the proposed hybrid observer is illustrated in Figure 1. It is composed of two blocks: a *location observer*, and a *continuous observer*.

The *location observer* receives as input the plant inputs (σ, u) and outputs (ψ, y) . Its task is to provide the estimate \tilde{q} of the discrete location q of the

¹ This event is introduced to model different possible situations for the discrete dynamics. For example, if $\phi(q, x, u) = \{\epsilon\}$, then there is no discrete transition enabled while if $\phi(q, x, u) = \{\sigma_1, \epsilon\}$, then it is possible either to let time pass or to take the discrete transition associated to σ_1 . Moreover, if $\phi(q, x, u) = \{\sigma_1\}$, then the discrete transition associated to σ_1 is forced to occur. This is useful for example to model internal transitions due to the continuous state hitting a guard.

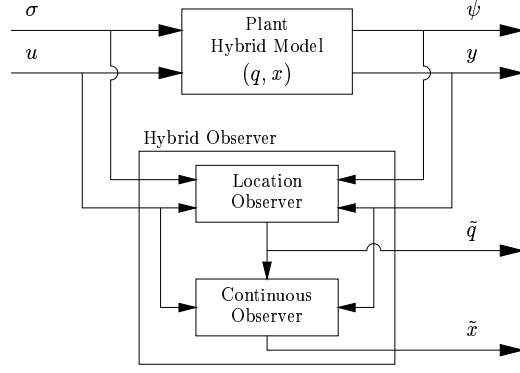

Fig. 1. Observer structure: location observer H_l and continuous observer H_c .

hybrid plant at the current time. This information is used by the *continuous observer* to construct an estimate \tilde{x} of the plant continuous state that converges exponentially to x . The continuous plant input u and output y are used by the continuous observer to this purpose.

3 Location and continuous observers decoupled synthesis

In this section, necessary and sufficient conditions for a decoupled design of a location observer and a continuous observer achieving exponential convergence according to Definition 1 are given.

3.1 Location-observer design

Definition 2. Let us denote by \mathcal{M} the FSM associated to the hybrid plant H_p defined by (1),

$$\sigma(k+1) \in \hat{\phi}(q(k)) = \bigcup_{x \in X, u \in U} \phi(q(k), x, u)$$

and (3). The FSM \mathcal{M} is said to be *current-location observable* if there exists an integer K such that for any unknown initial location $q_0 \in Q$ and for every input sequence $\sigma(k)$ the location $q(i)$ can be determined for every $i > K$ from the observation sequence $\psi(k)$ up to i .

An observer \mathcal{O} that gives estimates of the location $q(k)$ of \mathcal{M} after each observation $\psi(k)$ is the FSM

$$\tilde{q}(k+1) \in \varphi_{\mathcal{O}}(\tilde{q}(k), \psi(k+1)) \quad (8)$$

$$\psi_{\mathcal{O}}(k+1) = \tilde{q}(k) \quad (9)$$

with $Q_{\mathcal{O}} \in 2^Q$, $\Sigma_{\mathcal{O}} = \Psi$, $\Psi_{\mathcal{O}} = Q_{\mathcal{O}}$. The input of the observer is the output $\psi(k)$ of \mathcal{M} and the output produced by \mathcal{O} is an estimate $\tilde{q}(k)$ of the location

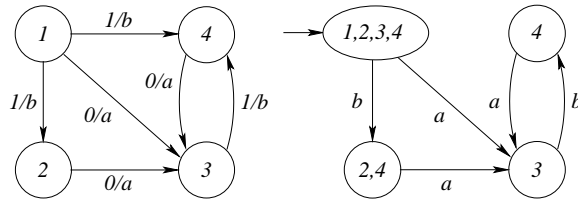

Fig. 2. A simple FSM \mathcal{M} (left) and its observer \mathcal{O} (right).

$q(k)$, representing the subset of Q of possible locations into which \mathcal{M} could have been transitioned after the k -th event. The observer transition function $\varphi_{\mathcal{O}}$ is constructed by inspection of the given FSM following the algorithm for the computation of the *current-location observation tree* as described in [6]. The construction starts from the initial location $\tilde{q}(0)$ of \mathcal{O} : since the initial location of \mathcal{M} is unknown, then $\tilde{q}(0) = Q$. When the first input event $\psi(1)$ is received, then the observer makes a transition to the location \tilde{q} corresponding to the set

$$\{q \mid \exists s \in Q : q \in \varphi(s, \sigma), \text{ with } \sigma \in \hat{\phi}(s) \text{ such that } \psi(1) = \eta(s, \sigma)\}$$

that depends on the value of $\psi(1)$. In fact, the number of observer locations at the second level depends on the number of possible events $\psi(1)$. By iterating this step, one can easily construct the third level of the tree whose nodes correspond to the sets of possible locations into which \mathcal{M} transitioned after the second event. Since this procedure produces at most $2^N - 1$ observer locations, then the construction of the observer necessarily ends.

Consider for example the FSM \mathcal{M} in figure 2 for which $Q = \{1, 2, 3, 4\}$, $\Sigma = \{0, 1\}$ and $\Psi = \{a, b\}$. The observer \mathcal{O} of this FSM has four locations, i.e. $Q_{\mathcal{O}} = \{\{1, 2, 3, 4\}, \{2, 4\}, 3, 4\}$ (see figure 2).

The following theorem gives necessary and sufficient conditions for an FSM to be current-location observable. The theorem has its origins in a result of [12], where a different definition of observability was considered.

Theorem 1. *An FSM \mathcal{M} is current-location observable iff for the corresponding observer \mathcal{O} defined as in (8–9):*

- (i) *the set $Q \cap Q_{\mathcal{O}}$ is nonempty;*
- (ii) *every primary cycle $Q_c^i \subset Q_{\mathcal{O}}$ includes at least one location in Q , i.e. the set $Q_c^i \cap Q$ is nonempty²;*
- (iii) *the subset $Q \cap Q_{\mathcal{O}}$ is $\varphi_{\mathcal{O}}$ -invariant³.*

Hence, if conditions (i), (ii) and (iii) of Theorem 1 are satisfied by the FSM associated to the hybrid plant H_p , then the hybrid observer can be obtained by a decoupled synthesis of the location observer and the continuous observer. The

² This condition corresponds to that of prestability of \mathcal{O} with respect to the set $Q \cap Q_{\mathcal{O}}$, as introduced in [13].

³ Following [13], a subset S is said to be φ -invariant if $\bigcup_{q \in S} \varphi(q, \phi(q)) \subset S$.

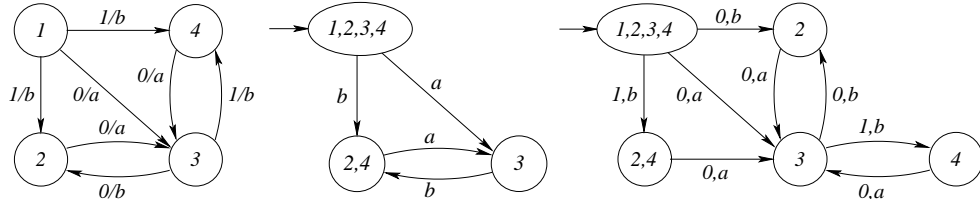

Fig. 3. FSM $\widetilde{\mathcal{M}}$ (left) and its observers without (center) and with (right) inputs measurements.

location observer H_l coincides with the observer \mathcal{O} described above and fulfils condition (6) of Definition 1 with location observer transitions synchronous with hybrid plant transitions.

The following examples illustrate how Theorem 1 works. For the FSM \mathcal{M} and the corresponding observer \mathcal{O} in figure 2: $Q \cap Q_{\mathcal{O}} = \{3, 4\}$ and the only cycle Q_c^1 of \mathcal{O} is composed of locations in Q , i.e. $Q_c^1 = \{3, 4\}$. Moreover it is easy to verify that the set $Q \cap Q_{\mathcal{O}}$ is invariant. Then, \mathcal{M} is current–location observable. Consider next the FSM $\widetilde{\mathcal{M}}$ and its observer $\widetilde{\mathcal{O}}$ in Figure 3. The observer has three locations: $Q_{\mathcal{O}} = \{\{1, 2, 3, 4\}, \{2, 4\}, 3\}$, $Q \cap Q_{\mathcal{O}} = \{3\}$ and the only cycle Q_c^1 of $\widetilde{\mathcal{O}}$ includes location 3, i.e. $Q_c^1 = \{\{2, 4\}, 3\}$. However, since location 3 is not invariant, then $\widetilde{\mathcal{M}}$ is not current–location observable. Note that while it is easy to check whether conditions (i) and (ii) of Theorem 1 are satisfied, verifying condition (iii) is more involved. An algorithm of complexity $O(N)$ to check φ -invariance can be found in [13].

Assuming measurability of the input sequence $\sigma(k)$, current–location observability can be redefined by replacing in Definition 2 the sequence $\psi(k)$ with the sequence $(\sigma(k), \psi(k))$. The knowledge of the input sequence may help in the estimation process. For instance, the FSM $\widetilde{\mathcal{M}}$ becomes current–location observable when both input and output sequences are considered as shown in figure 3.

3.2 Continuous observer design

The continuous observer H_c is a switching system whose dynamics depend on the current estimate \tilde{q} of the hybrid plant location q provided by the location observer. The scheme of the continuous observer is readily obtained using the classical Luenberger’s approach [10]:

$$\dot{\tilde{x}}(t) = F_i \tilde{x}(t) + B_i u(t) + G_i y(t) \quad \text{if } \tilde{q} = q_i. \quad (10)$$

where $F_i = (A_i - G_i C_i)$. If $q = q_i$, the corresponding dynamics of the observation error $\zeta = \tilde{x} - x$ is $\dot{\zeta}(t) = F_i \zeta(t)$. The gain matrix G_i is the design parameter used to set the velocity of convergence in each location. As pointed out in [2], the stabilization of this continuous observer is more complex than the stabilization of a single dynamics in (10) and can be achieved using the results on hybrid systems

stabilization presented in [5] and [16]. In particular, exponential convergence of the hybrid observer is guaranteed by the following lemma:

Lemma 1. *Assume that*

- **H1:** *for $i = 1 : N$, all couples (A_i, C_i) in (4–5) are observable;*
- **H2:** *the hybrid system H_p exhibits transitions with time separation greater than or equal to some $D > 0$;*
- **H3:** *the location observer H_l identifies instantaneously changes in the hybrid system location.*

The proposed hybrid observer H_l – H_c is exponentially convergent, with a given rate μ and convergence error $M_0 = 0$, if gains G_i in (10) are chosen such that

$$\alpha(A_i - G_i C_i) + \frac{\log[nk(A_i - G_i C_i)]}{D} \leq -\mu \quad (11)$$

where $\alpha(A)$ is the spectral abscissa of the matrix A and $k(A) = \|T\| \|T^{-1}\|$ with T such that $T^{-1}AT$ is in the Jordan canonical form.

The proof of this lemma can be obtained as a simplification of that of Theorem 4 reported in Section 4.2. Notice that condition **H3** is guaranteed by the current–location observability of the FSM associated to H_p assumed in this section.

Remark 1. A solution to the problem of exponentially stabilizing switching systems can be obtained from Lemma 1, with regard to the class of systems satisfying: controllability of all couples (A_i, B_i) (in place of **H1**), the transition separation property **H2** and with either known or observable current location q_i . For such systems, the problem of exponential stabilization reduces to the existence of state feedback gains K_i satisfying $\alpha(A_i - B_i K_i) + \log[nk(A_i - B_i K_i)]/D \leq -\mu$.

4 Location and continuous observers interacting synthesis

When the evolutions of the discrete inputs and outputs of the hybrid plant are not sufficient to estimate the current location, the continuous plant inputs and outputs can be used to obtain some additional information that may be useful for the identification of the plant current location. In Section 4.1, a methodology for selecting where the continuous information should be supplied and how it should be processed is described. The processing of the continuous signals of the plant gives reliable discrete information only after some delay with respect to plant location switchings. This results in a coupling between the location observer parameters and the continuous observer parameters as described in Section 4.2.

4.1 Location–observer design

When the FSM describing the discrete evolution of the hybrid plant is not current–location observable from the available input/output discrete sequences,

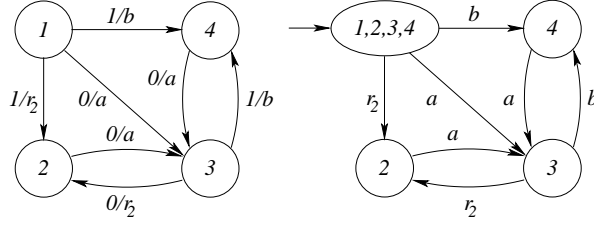

Fig. 4. The system $\widehat{\mathcal{M}}$ (left) and its observer $\widehat{\mathcal{O}}$ (right).

then, in order to estimate the current–location, it is natural to turn to the information available from the continuous evolution of the plant. In particular, residual signals can be used to detect a change in the continuous dynamics of the plant and the resulting signatures can be used as additional inputs to the current–location observer described in Section 3.1.

Introduction of signatures. Consider for example the system $\widetilde{\mathcal{M}}$ in Figure 3 and assume that only the discrete plant output ψ is available. Assume also that a signature r_2 can be produced for detecting the continuous dynamics associated to state 2. Then, when the system enters state 2, signal r_2 is available and can be used as an input for the discrete observer. A representation of the FSM associated to the hybrid plant plus the generator of the signature r_2 can be obtained by adding an output r_2 to each arc entering location 2. By doing this the FSM $\widehat{\mathcal{M}}$ shown in Figure 4 is obtained from $\widetilde{\mathcal{M}}$. By the introduction of signature r_2 , $\widehat{\mathcal{M}}$ is now current–location observable. Figure 4 shows the observer of $\widehat{\mathcal{M}}$, obtained applying the synthesis described in Section 3.1. In the general case, if the discrete representation of a given hybrid plant H_p is not current–location observable, then one may introduce a number of signatures detecting some of the different continuous dynamics of the plant to achieve current–location observability for the combination of the hybrid plant and the signature generator. Necessary and sufficient conditions for current–location observability of the composition hybrid plant and the signature generator are given in Theorem 1. If dynamics parameters in (4–5) are different in each location, then current–location observability can always be achieved in this way. The complete scheme of the location observer is shown in Figure 5. The *signatures generator* is described in the following Section. The *location identification logic* is a discrete observer synthesized as described in Section 3.1.

Signatures generator. The task of the signature generator is similar to that of a fault detection and identification algorithm (see [11] for a tutorial). Indeed, the signatures generator has to decide whether or not the continuous system is obeying to a particular dynamics in a set of known ones. Assuming that the location observer has properly recognized that the hybrid plant H_p is in location q_i , i.e. $\tilde{q} = q_i$, then the location observer should detect a fault from the evolution of $u(t)$ and $y(t)$ when the plant H_p changes the location to some $q_j \neq q_i$ and should identify the new location q_j . The time delay in the location

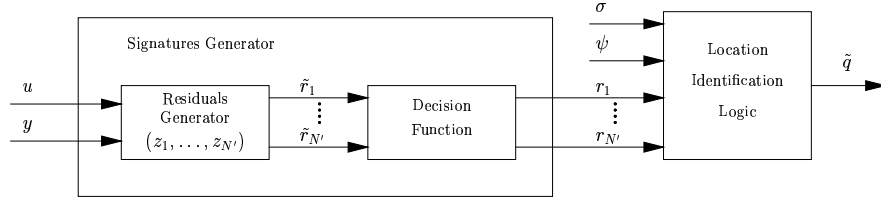

Fig. 5. Location observer structure.

change detection and identification is critical to the convergence of the overall hybrid observer. We denote by Δ an upper bound for such delay.

Since, when a change of location occurs, the continuous dynamics of the plant suddenly change, then the fault detection algorithms of interest are those designed for abrupt faults [7]. The general scheme is composed of three cascade blocks: the *residuals generator*, the *decision function*, and the fault decision logic, renamed here *location identification logic*, see Figure 5. The *signature generator* is the pair residuals generator–decision function. Assume that, in order to achieve current–location observability for the discrete evolution of the hybrid plant H_p , the signature generator has to detect N' different continuous dynamics (4–5) associated to a subset of states $\mathcal{R} \subseteq Q$. The simplest and most reliable approach for our application is to use a bank of N' Luenberger observers (see [7]), one for each plant dynamics in \mathcal{R} , as residual generators:

$$\dot{z}_j(t) = H_j z_j(t) + B_j u(t) + L_j y(t) \quad (12)$$

$$\tilde{r}_j(t) = C_j z_j(t) - y(t) \quad (13)$$

where $H_j = A_j - L_j C_j$ and L_j are design parameters. The N' residual signals \tilde{r}_j are used to identify the continuous dynamics the plant is obeying to. Indeed, no–vanishing residuals $\tilde{r}_j(t)$ correspond to $j \neq i$. The decision function outputs N' binary signals as follows:

$$r_j(t) = \begin{cases} true & \text{if } \|\tilde{r}_j(t)\| \leq \varepsilon \\ false & \text{if } \|\tilde{r}_j(t)\| > \varepsilon \end{cases} \quad \text{for } j = 1, \dots, N' \quad (14)$$

where the threshold ε is a design parameter. In the following theorem, a sufficient condition for ensuring $r_i = true$ in a time Δ after a transition of the hybrid plant H_p to a dynamics (A_i, B_i, C_i) is presented.

Theorem 2. For a given $\Delta > 0$, $\varepsilon > 0$ and a given upper bound Z_0 on $\|x - z_i\|$, if the estimator gains L_i in (12) are chosen such that

$$\alpha(H_i) \leq -\frac{1}{\Delta} \log \frac{n \|C_i\| k(H_i) Z_0}{\varepsilon} \quad (15)$$

then r_i becomes true before a time Δ elapses after a change in the plant dynamics parameters to the values (A_i, B_i, C_i) .

Consider the j -th residual generator and assume that there is a transition from location q_j to location q_i , so that the continuous state x of H_p is governed by dynamics defined by parameters $(A_i, B_i, C_i) \neq (A_j, B_j, C_j)$. Unfortunately, as shown for example by the following theorem, there are cases where we cannot prevent the signal r_j from remaining *true* for an unbounded time:

Theorem 3. *If the matrix $(C_j - C_i)B_i + C_j(B_i - B_j)$ is invertible, with $i \neq j$, then for any hybrid plant initial condition, the class of plant inputs $u(t)$ that achieves $r_j(t) = \text{true}$ for all $t > \Delta$ after a change in the plant dynamics parameters to (A_i, B_i, C_i) is not empty.*

In the general case, the set of configurations and the class of plant inputs for which the signatures (14) fail to properly identify the continuous dynamics can be obtained by computing the maximal safe set and the maximal controller for dynamics (4–5) and (12–13) with respect to a safety specification defined in an extended state space that contains an extra variable τ representing the elapsed time after a plant transition. More precisely, the set of configurations for which a wrong signature may be produced up to a time $t' > \Delta$ after a plant location change, is given by those configurations $(0, x^0, z_j^0)$ from which there exists a plant continuous input $u(t)$ able to keep the trajectory inside the set $[0, t'] \times \{(x, z_j) \in \mathbb{R}^{2n} \mid \|C_j z_j - C_i x\| \leq \varepsilon\}$. However, since in practical applications the resulting maximal controller is very small, the case of non proper identification is unlikely to occur.

4.2 Continuous observer design

The continuous observer⁴ is designed as in the previous case (see Section 3.2). Exponential convergence of the continuous observer is analyzed considering the complete hybrid system obtained by composing the hybrid model H_p and the observer hybrid model H_l and H_c . The overall hybrid system has $N \times N$ locations of type (q_i, \tilde{q}_j) , the former corresponding to plant locations and the latter corresponding to observer locations. To each location (q_i, \tilde{q}_j) , the continuous dynamics

$$\dot{x}(t) = A_i x(t) + B_i u(t) \quad (16)$$

$$\dot{\zeta}(t) = F_j \zeta(t) + [(A_i - A_j) - G_j(C_i - C_j)]x(t) + (B_i - B_j)u(t) \quad (17)$$

is associated. By integrating (17) we have

$$\zeta(t) = e^{F_j t} \zeta(0) + e^{F_j t} \star v(t) \quad (18)$$

where \star denotes the convolution operator and $v(t) = [(A_i - A_j) - K(C_i - C_j)]x(t) + (B_i - B_j)u(t)$. The following notation will be used in the sequel ([15]):

⁴ The Luenberger observers (12) contained in the residual generators, which are designed to converge to the same state variable x , do not provide a satisfactory estimate of the evolution of x since they are tuning according to (15) in order to meet the specification of producing a residual with a transient time less than Δ . Hence, they exhibit a large overshoot which is undesirable for feedback purpose.

$\|m(t)\|_\infty = \max_{k=1,q} \sup_{t \geq 0} |m_k(t)|$, the L^∞ -norm of q -dimensional signals $m: \mathbb{R} \rightarrow \mathbb{R}^q$; $\|M\|_\infty$ and $\|M\|_1$ the L^∞ and the L^1 -norm of a matrix M , respectively.

Theorem 4. *Assume that*

- **H1:** for $i = 1 : N$, all couples (A_i, C_i) in (4-5) are observable;
- **H2:** there exist $X > 0$ and $U > 0$, such that $\|x(t)\|_\infty \leq X$ and $\|u(t)\|_\infty \leq U$, so that

$$\|v(t)\|_\infty \leq V = \max_{q_i, q_j \in \mathcal{R}} \|[(A_i - A_j) - G_j(C_i - C_j)]\|_1 X + \|B_i - B_j\|_1 U \quad (19)$$

- **H3:** the hybrid system H_p exhibits transitions with time separation greater than or equal to some $D > 0$.

Given a $\mu > 0$ and an $M_0 > 0$, if the observer gains G_i are chosen such that

$$\alpha(A_i - G_i C_i) + \frac{\log[nk(A_i - G_i C_i)]}{\beta} \leq -\mu \quad (20)$$

for some $\beta \in (0, D)$, and if

- **H4:** the location observer H_l identifies a change in the hybrid system location within time

$$\Delta \leq \min \left\{ \min_{q_i \in \mathcal{R}} \frac{1 - e^{-\mu\beta}}{n\sqrt{n}k(A_i - G_i C_i)V} M_0, D - \beta \right\} \quad (21)$$

then the proposed hybrid observer H_l - H_c is exponentially convergent with rate μ and convergence error M_0 .

Proof. Consider two subsequent transitions of the hybrid plant H_p , occurring at times t_k and t_{k+1} respectively. By hypothesis **H1**, $t_{k+1} - t_k \geq D$. Since by **H4**, $\Delta \leq D - \beta$, the location observer H_l identifies the k -th and $k + 1$ -th state transitions at some times t'_k and t'_{k+1} , respectively, with $t'_k - t_k \leq \Delta$ and $t'_{k+1} - t_{k+1} \leq \Delta$. Furthermore, notice that, by **H3** and **H4**, $t'_{k+1} - t'_k \geq t_{k+1} - t'_k \geq D - \Delta \geq \beta > 0$. Since $\tilde{q} = q$ in the time interval $[t'_k, t_{k+1}]$, then, by condition **H1** on observability of dynamics (4-5), convergence to zero of $\zeta(t)$ at any desired velocity can be obtained by proper choice of gains G_j . In particular, observer gains G_j satisfying inequality (20), for some $\beta \in (0, D)$, can be selected. However, since $\tilde{q} \neq q$ when $t \in [t_{k+1}, t'_{k+1}]$, $\zeta(t)$ may fail to converge later. Hence, the convergent behavior for $t \in [t'_k, t_{k+1}]$ has to compensate the divergent behavior for $t \in [t_{k+1}, t'_{k+1}]$. By (18), we have

$$\zeta(t) = e^{F_j(t-t'_k)} \zeta(t'_k) + \int_0^{t-t'_k} e^{F_j(t-t'_k-\tau)} v(\tau + t'_k) d\tau \quad \forall t \in (t'_k, t'_{k+1}] \quad (22)$$

where $v(t) = 0$ for $t \in (t'_k, t_{k+1}]$. By the Lemma 2 reported in appendix, the evolution of the transient term can be bounded as follows

$$\|e^{F_j(t-t'_k)} \zeta(t'_k)\| \leq nk(F_j) e^{\alpha(F_j)(t-t'_k)} \|\zeta(t'_k)\| \quad (23)$$

Furthermore, for the forced term, since by **H4** $t - t_{k+1} \leq \Delta$, we have

$$\begin{aligned} & \left\| \int_0^{t-t'_k} e^{F_j(t-t'_k-\tau)} v(\tau + t'_k) d\tau \right\| \leq nk(F_j) \int_0^{t-t_{k+1}} e^{\alpha(F_j)(t-t_{k+1}-\tau)} \|v(\tau + t_{k+1})\| d\tau \\ & \leq nk(F_j) \sup_{t \geq 0} \|v(t)\| \int_0^{t-t_{k+1}} e^{\alpha(F_j)\tau} d\tau \leq n\sqrt{n}k(F_j) \|v(t)\|_\infty \frac{e^{\alpha(F_j)(t-t_{k+1})} - 1}{\alpha(F_j)} \\ & \leq n\sqrt{n}k(F_j)V(t - t_{k+1}) \leq n\sqrt{n}k(F_j)V\Delta \quad \forall t \in [t_{k+1}, t'_{k+1}] \end{aligned} \quad (24)$$

Then, using (21), by (23) and (24), equation (22) can be upper bounded as follows

$$\|\zeta(t)\| \leq nk(F_j)e^{\alpha(F_j)(t-t'_k)} \|\zeta(t'_k)\| + (1 - e^{-\mu\beta}) M_0 \quad \forall t \in (t'_k, t'_{k+1}] \quad (25)$$

Hence, the evolution of the norm of the observation error $\|\zeta(t)\|$ is upper bounded by the evolution of a hybrid system as described in Lemma 3 reported in appendix, with $\gamma = \alpha(F_j)$, $a = nk(F_j)$, $b = (1 - e^{-\mu\beta}) M_0$, and continuous state resets separation greater than or equal to β .

Then, by Lemma 3, if the observer gains are chosen according to (20), the observation error converges exponentially to the set

$$\|x - \tilde{x}\| = \|\zeta(t)\| \leq \frac{b}{(1 - e^{-\mu\beta})} = M_0$$

with velocity of convergence greater than or equal to $-\mu$.

Q.E.D.

5 Using guards to improve continuous state estimation

In some cases the detection of a discrete transition in the hybrid plant can be used to improve the convergence of the observer continuous state \tilde{x} to the plant continuous state x . Indeed, as represented in (2), plant discrete transitions may depend on the value of plant continuous state x through the guards modelled by functions $\phi(\cdot)$.

A simple case is when complete information on the plant continuous state x can be obtained at some time from the detection of a plant discrete transition. This allows the continuous observer to jump to the current value of the plant continuous state, zeroing instantaneously the observation error. Suppose that the plant is in location q_i and that, at some time t_k , the event σ_j that produces a forced transition corresponding to the state x hitting a guard is identified. Instantaneous detection of the plant continuous state can be achieved if the following system of equation admits a unique solution for x :

$$\begin{aligned} C_i x &= y(t_k^-) \\ \sigma_j &\in \phi(q_i, x, u(t_k^-)) \end{aligned} \quad (26)$$

A similar condition can be used to obtain open loop observers for the components of the continuous plant state that lie on the unobservable subspace, when condition **H1** in either Lemma 1 or in Theorem 4 is not fulfilled. Instantaneous detection of the not observable components of the continuous plant state can be achieved if equations (26) admit a unique solution for them.

Conclusions

A methodology for the design of exponentially convergent dynamical observers for hybrid plants has been presented. In the proposed hybrid dynamical observer, a location observer and a continuous observer provide, respectively, estimates of the plant current location and continuous state. Both the case where the current plant location can be reconstructed by using discrete input/output information only, and the more complex case where some additional information from the continuous evolution of the plant is needed to this purpose have been considered.

References

1. G. A. Ackerson and K. S. Fu. On state estimation in switching environments. *IEEE Trans. on Automatic Control*, 15(1):10–17, 1970.
2. A. Alessandri and P. Coletta. Design of luenberger observers for a class of hybrid linear systems. In *Hybrid Systems: Computation and Control*, volume 2034 of *LNCS*, pages 7–18. Springer–Verlag, Berlin Heidelberg, 2001.
3. A. Balluchi, L. Benvenuti, M. D. Di Benedetto, C. Pinello, and A. L. Sangiovanni-Vincentelli. Automotive engine control and hybrid systems: Challenges and opportunities. *Proceedings of the IEEE*, 88, "Special Issue on Hybrid Systems" (invited paper)(7):888–912, July 2000.
4. A. Balluchi, L. Benvenuti, M. D. Di Benedetto, and A. L. Sangiovanni Vincentelli. A hybrid observer for the driveline dynamics. In *Proc. of the European Control Conference 2001*, pages 618–623, Porto, P, 2001.
5. M. Branicky. Multiple lyapunov functions and other analysis tools for switched and hybrid systems. *IEEE Trans. on Aut. Contr.*, 43(4):475–482, 1998.
6. P. E. Caines, R. Greiner, and S. Wang. Dynamical logic observers for finite automata. In *Proceedings of 27th Conference on Decision and Control*, pages 226–233, Austin, TX, 1988.
7. P. M. Frank. Fault diagnosis in dynamic systems using analytical and knowledge-based redundancy — a survey and some new results. *Automatica*, 26(3):459–474, 1990.
8. Y. Liu. Switching observer design for uncertain nonlinear systems. *IEEE Trans. on Automatic Control*, 42(1):1699–1703, 1997.
9. C. Van Loan. The sensitivity of the matrix exponential. *SIAM Journal of Number Analysis*, 14(6):971–981, December 1977.
10. D.G. Luenberger. An introduction to observers. *IEEE Transactions on Automatic Control*, 16(6):596–602, Dec 1971.
11. M.-A. Massoumnia, G.C., Verghese, and A.S. Willsky. Failure detection and identification. *IEEE Transactions on Automatic Control*, 34(3):316–21, March 1989.
12. C. M. Özveren and A. S. Willsky. Observability of discrete event dynamic systems. *IEEE Trans. on Automatic Control*, 35:797–806, 1990.
13. C. M. Özveren, A. S. Willsky, and P. J. Antsaklis. Stability and stabilizability of discrete event dynamic systems. *Journal of the Association for Computing Machinery*, 38:730–752, 1991.
14. P. J. Ramadge. Observability of discrete event–systems. In *Proceedings of 25th Conference on Decision and Control*, pages 1108–1112, Athens, Greece, 1986.
15. M. Vidyasagar. *Nonlinear Systems Analysis*. Prentice–Hall, Inc, Englewood Cliffs, N.J., 1978.

16. H. Ye, A. N. Michel, and L. Hou. Stability theory for hybrid dynamical systems for switched and hybrid systems. *IEEE Trans. on Automatic Control*, 43(4):461–474, 1998.
17. Q. Zhang. Hybrid filtering for linear systems with non-baussian disturbances. *IEEE Trans. on Automatic Control*, 45(1):50–61, 1999.

Appendix

Lemma 2 ([9]). *Let A be a matrix in $\mathbb{R}^{n \times n}$. Then*

$$\|e^{A\tau}\| \leq n k(A) e^{\alpha(A)\tau} \quad \forall \tau \geq 0 \quad (27)$$

where $\alpha(A)$ is the spectral abscissa (i.e. the maximal real part of the eigenvalues) of matrix A and $k(A) = \|T\| \|T^{-1}\|$ with T such that $T^{-1}AT$ is in the Jordan canonical form.

Lemma 3. *Consider a single-location hybrid system with a scalar continuous variable x . Let x be subject to the dynamics $\dot{x} = \gamma x$, with $\gamma < 0$, and to the resets $x(t_k) := ax(t_k^-) + b$ occurring at some unspecified sequence of times $\{t_k\}$, with $a \geq 1$ and $b \geq 0$. The evolution of $x(t)$ can be described as follows*

$$x(t) = e^{\gamma(t-t_{k-1})}x(t_{k-1}) \quad \text{for } t \in [t_{k-1}, t_k) \quad (28)$$

$$x(t_k) = ax(t_k^-) + b = ae^{\gamma(t_k-t_{k-1})}x(t_{k-1}) + b \quad (29)$$

Assume that there exists a lower bound β on reset events separation, i.e. $t_k - t_{k-1} \geq \beta > 0$ for all $k > 1$.

If $x(t_0) > 0$ and $\gamma + \frac{\log a}{\beta} = -\mu < 0$, then $x(t)$ converges exponentially to the set $[0, \frac{b}{1-e^{-\mu\beta}}]$ with rate of convergence equal to or greater than μ .

Proof. By (29), since $e^{-\mu(t_k-t_{k-1})} \leq e^{-i\mu\beta}$ then

$$\begin{aligned} x(t_k) &\leq e^{\frac{\log a}{\beta}(t_k-t_{k-1})} e^{\gamma(t_k-t_{k-1})}x(t_{k-1}) + b = e^{-\mu(t_k-t_{k-1})}x(t_{k-1}) + b \\ &\leq e^{-\mu(t_k-t_0)}x(t_0) + b \sum_{i=0}^{k-1} e^{-i\mu\beta} < e^{-\mu(t_k-t_0)}x(t_0) + \frac{b}{1-e^{-\mu\beta}} \end{aligned}$$

This proves that, after each reset the value $x(t_k)$ of the state is upper bounded by an exponential with rate $-\mu$ that converges to the point $\frac{b}{1-e^{-\mu\beta}}$. This shows exponential convergence to the set $[0, \frac{b}{1-e^{-\mu\beta}}]$ at resets times t_k . Readily, the same results can be extended to the open intervals between resets times by noting that during the continuous evolution the rate of convergence $-\gamma$ is lower than $-\mu$. **Q.E.D.**